



FITTING INSTRUCTIONS FOR

# 30L Underbody Water Tank

PART NUMBER

**KS0163**

COMPATIBILITY

**Toyota Prado 150, Lexus GX 460**

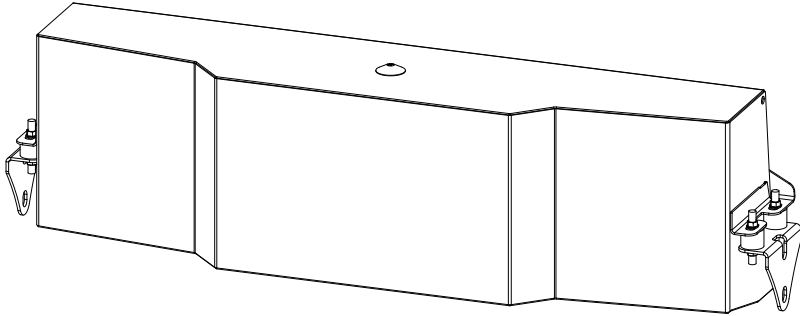

## Included contents

QTY	COMPONENT	QTY	COMPONENT
1	30L Water Tank	1m	8mm Clear Hose
2	Mounting Bracket	4	M8 x 25 Rubber Isolator
190mm	6mm Clear Hose	8	M8 Flanged Nuts
2	1/8 NPT x 6mm Push On Banjo Fitting	1	15mm Chrome Tap
2	1/8 NPT x 8mm Push On Fitting	1	15mm Brass Extension
2	1/4 Brass Breather	1	Roll of Teflon Thread Tape
2	1/4 Female NPT x 8mm Push On Fitting	1	Warning Sticker



**Time**

2 hours / Couple of beers

Scan the **QR code** to watch the video installation guide,  
or for further information contact KAON on **07 3180 1470** or [info@kaon.com.au](mailto:info@kaon.com.au)



### G8.8 Bolt Torque

DIAMETER (mm)	5mm	6mm	8mm	10mm	12mm	14mm
LUBRICATED (Nm)	5 Nm	8 Nm	16 Nm	33 Nm	56 Nm	84 Nm
NON-LUBRICATED (Nm)	6 Nm	10 Nm	22 Nm	44 Nm	77 Nm	112 Nm

# Let's get to work.

## Preparation

We have comprehensive video instructions for this install. If you're a little unsure, we'd recommend using the QR code on the front page to find and watch these first.

1. Apply 4 or 5 turns of Teflon tape in a clockwise direction to the 2 x 90-degree banjo fittings and 4 x 8mm push on fittings.
2. The Banjo fittings are for the sight level.
3. Install these banjo fittings to the 2 tapped holes on the front flat face of the water tank. Do not over tighten. These have a tapered thread and need only be tightened firmly to seal. Do not wind all the way down.
4. Install the clear hose for the water level gauge between the banjo fittings of the front face of the tank. Push the hose firmly into the fitting to ensure a good seal.
5. Install the 8mm push on fittings to the two tapped holes on each of the upper sides of the tank.
6. Attach the brass breathers to the 1/4 female NPT 8mm push on fittings. Set these aside.

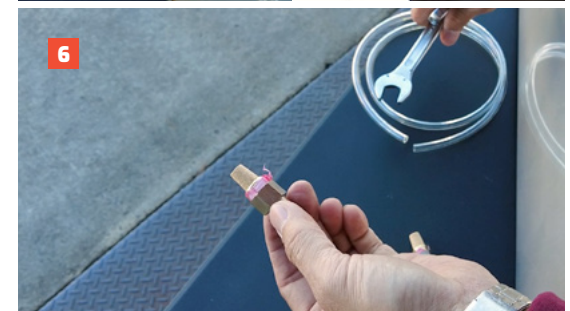

## Plumbing Installation

If you are installing this tank with the KAON Water Pump Kit (KS0593):

- Note:** These photos show the brass hardware being installed whilst the tank is on the vehicle, but we recommend installing it prior.
- Within the pump kit, locate the brass hoesetail barb, tee and nipple pieces.
- Apply teflon tape to all the brass fitting threads in a clockwise direction.
- Assemble the fitting as shown with the tap on one end and the nipple in line on the other end.

We recommend positioning the tap outlet facing backwards and the Tee outlet pointing up or slightly forward.

- Tightening the tap will tighten all the tee and nipple onto the tank. Note the desired final position of the tee outlet and the tap outlet and tighten individual components as required.
  - Attach the hoesetail barb fitting to the outlet of the Tee piece.
13. Continue with steps 18-32.

Once complete, move onto the pump install, using the fitting instructions provided as part of the Water Tank Pump Kit (KS0593).

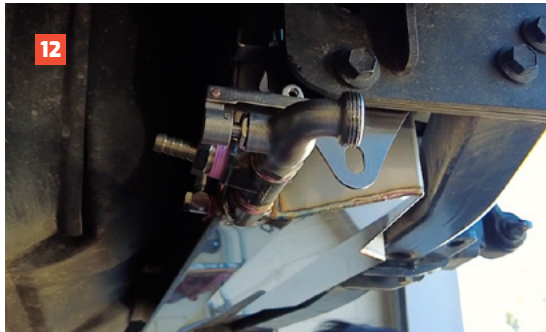

## Plumbing Installation

If you are installing this tank without the pump kit:

- Use the supplied Teflon tape to all threads on the tap and brass extension.
- Attach the brass extension to the 15mm threaded tank outlet.
- Attach the supplied tap.
- You may need to add more Teflon tape so that the tap is secure with the spout pointing to the vehicle rear (towards the bevelled back of the tank as pictured) once installed.



## Vehicle Preparation

18. Remove the plastic trim that covers the gap between the towbar and vehicle.
19. Ensure there are no wires or hoses in the cavity where the tank will be installed.
20. Attach the 4 rubber isolators to the underside of the mounts on the sides of the water tank, using the supplied M8 flanged nuts. The mounts are slotted, but we suggest mounting centrelling as generally that is correct on most vehicles.
21. Tighten to secure.
22. Remove towbar nuts and attach the towbar mounting bracket to the towbar using existing nuts. Attach loosely to the left-hand side only.
23. Remove the 2 x M10 bolts that attach the towbar to the side arms on the opposite side (the right hand side) and leave them just sitting in their mounting holes. This will make installing the tank much easier.



## Tank Installation

24. Lift the tank into position. Lift the left hand side up and ensure the isolators are sitting on top of the bracket.
25. Lift the right hand side up and position the mounting bracket and re-install the bolts that were removed from the towbar. The original towbar nuts are re-used.
26. Adjust the position of the tank to ensure even gap to the vehicle. You might need to remove the tank to adjust the position of the isolators and to tension the nuts on the top of the brackets. Ensure the tank chamber is not touching any part of the chassis or tow bar.
27. Cut the 8mm clear hose in half and push these into the fittings on upper sides of the tank. These are the breather hoses.
28. Push the breather hoses into the push on fittings on the upper sides of the tank.
29. Position the breather hoses under the vehicle and determine a suitable position for the breather which is higher than the top of the tank. Secure in place with a zip tie or similar. Ensure breather lines are clear and unobstructed.
30. Tighten and torque all bolts.
31. Adhere the supplied Warning Sticker adjacent to the tap.
32. **If you are installing the KAON pump kit, complete the fitting instructions provided for the Water Tank Pump Kit (KS0593), before continuing with steps 35-40.**

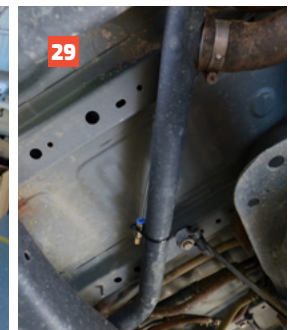
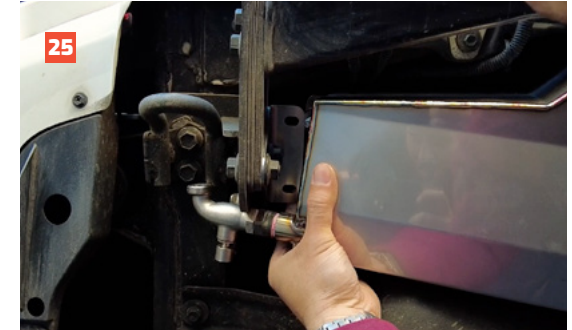

## Filling Guidelines

33. Attach a standard garden hose fitting to the end of the tap.
34. The tank is filled and drained from the same outlet. Ensure the tap is turned on in the open position to allow the water to enter the tank.
35. Fill to the desired level or until water escapes from the breathers.
36. Excessive pressure or flow may cause tank to swell. Turn off water as soon as tank is full.
37. If the breathers get wet, the flow from the outlet is reduced until they dry out. This is because the tank cannot breathe as freely when the breathers are wet.
38. We recommend rinsing and washing the tank by running a weak detergent solution through it prior to use.



### Local Knowledge & Assistance

We know half the fun of building your dream 4x4 is getting your hands dirty. But we also know that sometimes, things don't go to plan. If in the pursuit to build the ultimate setup you find yourself off-track, we're here to help you get unstuck.

For further information call 07 3180 1470 or email [info@kaon.com.au](mailto:info@kaon.com.au)

Disclaimer: The products sold by KAON should not be modified, and are for use only on the vehicles specifically stated. KAON will not be liable for any damages arising out of the use or misuse of its products. It is the customer's responsibility to ensure the products are safely and properly used and installed. KAON consistently seeks to improve its products and reserves the right to make changes to any product.



FITTING INSTRUCTIONS FOR

# Underbody Water Tank Pump Kit

SKU

**KS0593**

COMPATIBILITY

**KAON 30L Underbody Water Tank (KS0163)**

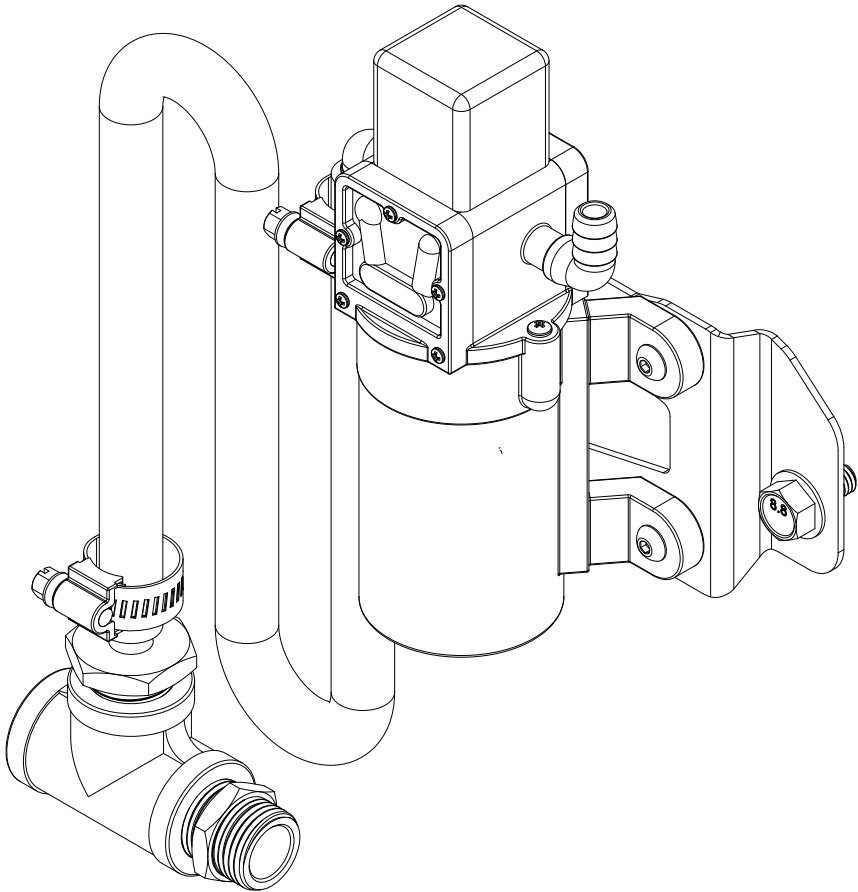

Scan the **QR code** to watch the video installation guide,  
or for further information contact KAON on **07 3180 1470** or [info@kaon.com.au](mailto:info@kaon.com.au)



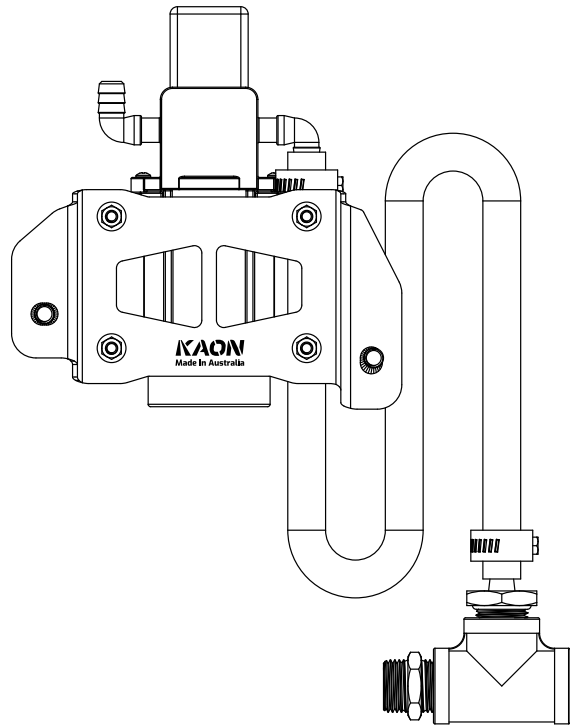

### Included contents

QTY	COMPONENT	QTY	COMPONENT
1	Seafo 3.8lpm Pump	600mm	10mm PVC Braided Hose
1	Pump Mounting Bracket	2	13-20mm Hose Clamp
4	M5 x 16 Button Head Socket Screw	1	Brass Hex Nipple 1/2" BSPP
4	M5 Nyloc Nut	1	Brass Tee 1/2" BSPP
2	M8 x 16 Flanged Hex Bolt G8.8	1	Brass Barb 10mm 1/2" BSPP

### Also required (not included)

Pump water outlet components based on your setup (For example: hose, clamps, tap fitting, etc)

Electrical supply & switching components

Any metering components (if desired)

# Let's get to work.

## Preparation

We provide everything you need to connect the pump to your tank. Due to setup variables, you will need to source materials required for the pumps output, as well as power supply and any metering you may wish to install.

If you are installing the tank as well, start with the instructions provided with it first. We have comprehensive video instructions for this install. If you're a little unsure, use the QR code on the front page to find and watch these first.

1. Attach the mounting bracket to the back of the pump using the provided M5 screws and nuts.
2. Ensure the bracket orientation is correct with the lowest part of the bracket at the bottom left of the pump, as pictured.
3. Tighten all bolts.
4. We provide a 600mm length of braided hose to connect the tank to the pump, but you will need to source a hose for the pumps output. The length of this will depend on where you intend the final water outlet to be located within your vehicle. See pg 7 for suggested possible access positions.
5. Attach the provided 600mm pump inlet hose to the left hand side of the pump using one of the provided hose clamps.
6. We recommend attaching the pump outlet water hose you have sourced to the right hand side at this point, as it is more difficult to access once the pump is mounted to the vehicle. We have attached a short piece to demonstrate.

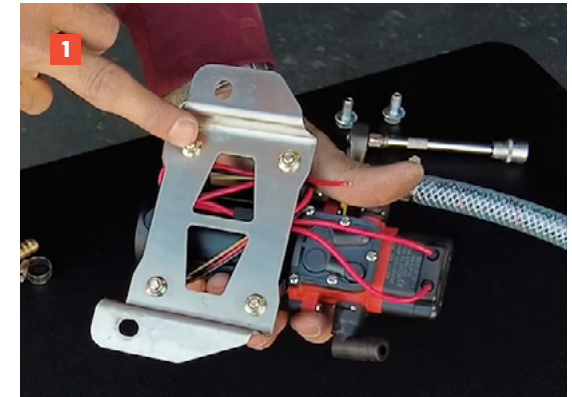

## Mounting the Pump

7. The pump bracket mounts to two captive nuts in the vehicle chassis, just behind the rear wheels on the LHS (AU Passenger) side.
8. You will see a rubber grommet above this position, this allows you to run power and water into/from the pump and into the car, if you wish to do that.
9. Lift it into position and secure using the provided M8 bolts.



## Installing the Brass Hardware to the Tank

**As part of a new tank install:**  
If you are installing the KAON Underbody Tank (KS0163) at the same time as this pump kit you will already have installed the provided brass tee, nipple and hosetail barb pieces to the tank's tap, in line with the tank instructions. Skip to step 18.

**To a previously installed tank:**

10. If you are installing this kit to a tank previously fitted (without a tee), we suggest you drop the tap side of the tank first. It can be held in place by loosely securing the top tank mount to the lower bolt.
11. Remove the brass tap and fitting from the tank outlet.
12. Apply teflon tape to all the brass fitting threads in a clockwise direction.
13. Assemble the fitting as shown with the tap on one end and the nipple in line on the other end.  

We recommend positioning the tap outlet facing backwards and the Tee outlet pointing up or slightly forward.
14. Tightening the tap will tighten all the tee and nipple onto the tank. Note the desired final position of the tee outlet and the tap outlet and tighten individual components as required.
15. Attach the hosetail barb fitting to the outlet of the Tee piece.

Applying more or less teflon to the threads will allow adjustment of the final position of both the tap and tee.

16. Lift the tank back up into its correct position, and tighten the mounting bolts to secure.

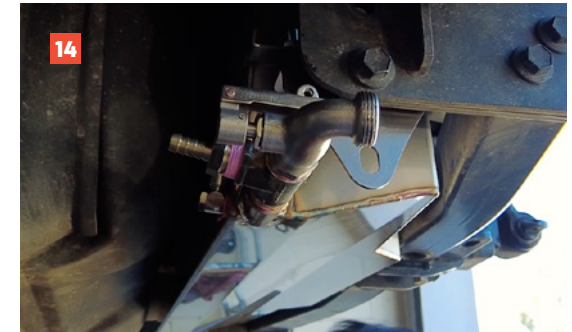
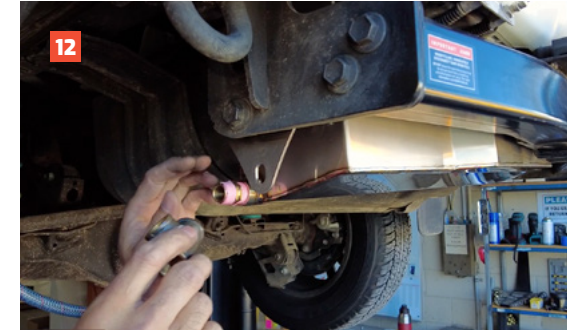

## Plumbing the Pump into the Tank

17. If you have opted to orient the hosetail pointing towards the front of the vehicle, loosely line up the 600mm pump inlet hose with the brass barb fitting on the tank outlet.

If you drive have opted to orient the hosetail upwards, run the hose higher up above the chassis rails before dropping down to connect to the tank.

18. With the hose position confirmed and trim to the final desired length. You don't want the hose to be pulled taut, but also ensure it is positioned without any excess slack.

19. Secure the trimmed hose to the nipple using the remaining provided hose clamp.

20. Ensure the hose is clear of any obstructions and that nothing is rubbing on it.

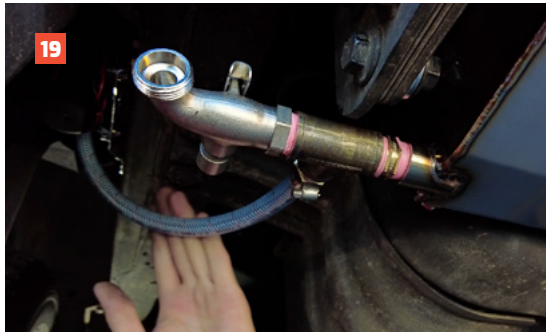

## Tips for finalising the installation

From here it's over to you!

We know that people have lots of different setups, so we haven't provided components or instructions on how to run the water or electrical from your pump.

But that doesn't mean we don't have some tips and suggestions:

- A. The grommet mentioned in Step 8 feed into the interior panel pictured, allowing you to run it into a drawer system with a switch and retractable hose on the drawer wings.
- B. You can run the water outlet across to this hatch and fit it with a swivelling tap.
- C. And perhaps the trickiest option (but definitely a game-changer) is to feed the water into a tap on your rear door.

This requires running the water line and power under the rear trim across the back of the car, through the rubber door grommets and into your rear door. 12V taps like this are available from caravan accessory retailers, as is the level meter pictured.

It's worth noting it's a lengthy install to complete and a lot of wiring and hoses need to make it through the rear door grommet. The level meter also requires a hole drilled into the tank for the water level sender.

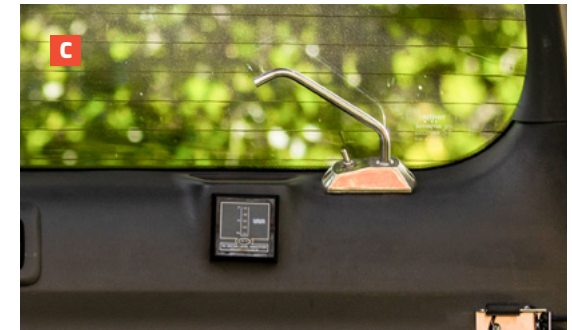

## G8.8 Bolt Torque

DIAMETER (mm)	5mm	6mm	8mm	10mm	12mm	14mm
LUBRICATED (Nm)	5 Nm	8 Nm	16 Nm	33 Nm	56 Nm	84 Nm
NON-LUBRICATED (Nm)	6 Nm	10 Nm	22 Nm	44 Nm	77 Nm	112 Nm



### Local Knowledge & Assistance

We know half the fun of building your dream 4x4 is getting your hands dirty. But we also know that sometimes, things don't go to plan. If in the pursuit to build the ultimate setup you find yourself off-track, we're here to help you get unstuck.

For further information call 07 3180 1470 or email [info@kaon.com.au](mailto:info@kaon.com.au)

Disclaimer: The products sold by KAON should not be modified, and are for use only on the vehicles specifically stated. KAON will not be liable for any damages arising out of the use or misuse of its products. It is the customers responsibility to ensure the products are safely and properly used and installed. KAON consistently seeks to improve its products and reserves the right to make changes to any product.